

Level Limit Switch *nivotester FTL 325 N*

**1-channel and 3-channel isolating amplifier
with NAMUR input for connecting any NAMUR
measuring sensor**



Applications

- Level limit detection in liquid tanks, also in hazardous explosion areas
- For Zone 0 or Zone 20 measuring sensors
- Liquid detection in pipes for dry running protection for pumps
- Overspill protection for tanks with combustible or non-combustible liquid harmful to water
- Two-point control and level limit detection with one switching instrument
- Application in safety related systems with requirements for functional safety up to SIL2 in accordance to IEC 61508 / IEC 61511 when using Liquiphant M/S with electronic insert FEL 58

Benefits at a glance

- Intrinsically safe signal circuits [EEx ia] for problem-free use of measuring sensor in explosion hazardous areas
- Functional safety SIL (see also Safety Manual SD 161F) through:
 - line monitoring through to sensor
 - corrosion monitoring on tuning fork of Liquiphant M and Liquiphant S (high temperature) measuring sensor
- Compact housing for simple series installation on standard rails in switch cabinet
- Simple wiring using pluggable terminal blocks
- NAMUR interface to EN 50227 (DIN 19234; NAMUR) or IEC 60947-5-6 to connect NAMUR sensors or electronic inserts.

Endress + Hauser

The Power of Know How



Functions and system design

Measuring principle

Signal transmission

The intrinsically safe signal input of the Nivotester FTL 325 N limit switch is galvanically isolated from the mains and the output.

The Nivotester supplies a DC voltage to the Liquiphant M and Liquiphant S (high temperature) measuring sensors with electronic inserts FEL 56 and 58 or a sensor specified to EN 50227 (DIN 19234; NAMUR) or IEC 60947-5-6 via a two-wire loop. At the same time, a control current is transferred along this supply line.

The control current ranges from < 1.2 mA to > 2.1 mA depending on the switching status.

Signal evaluation

The Nivotester measures and evaluates the control current which is transferred along the supply line of the sensors. The level alarm relay signals if the measuring sensor is covered or free and an LED on the front panel of the Nivotester displays the switching status of the relay. Faults such as a line interruption or short circuit are also displayed.

Fail-safe circuit

By correctly selecting the fail-safe circuit, you can ensure that the relay always operates in quiescent current safety. The error current signal of the connected sensor (< 1.2 mA or > 2.1 mA) for each channel can be set with the DIL switches on the Nivotester. This means that the isolating amplifier can be used for any application at the required operational safety level.

Combined with a level limit switch, quiescent current safety is defined as follows:

- Maximum safety: the relay drops out when the switching point is exceeded (measuring sensor covered), a fault occurs or the power supply fails.
- Minimum safety: the relay drops out when the switching point is undershot (measuring sensor uncovered), a fault occurs or the power supply fails.



Note!

For application with requirements for functional safety in accordance to IEC 61508 / IEC 61511 (SIL) please note Safety Manual SD 161F.

Function monitoring

To increase operational safety, the Nivotester is equipped with a function monitoring system. A fault is indicated by an LED and causes the level alarm relay in the affected channel as well as the fault alarm to drop out. A fault is signalled when the Nivotester receives no more control signals. This could occur for example in the event of a short-circuit, an interruption in the signalling line to the measuring sensor, vibrator corrosion in a measuring sensor, or a defect in the Nivotester input circuit. The function of each channel can be monitored by pressing the test button. The power supply to the sensor is then interrupted.

Two-point control (Δs)

Two-point control is possible in one tank using the Nivotester FTL 325 N-#3#3 (e.g. for pump control). The switching hysteresis is specified by the installation location of the two measuring sensors.

NAMUR Module

The FTL 325 N is equipped with a NAMUR interface to EN 50227 (DIN 19234; NAMUR) or IEC 60947-5-6. This means that control signals generated by the measuring sensor according to NAMUR Recommendations can be evaluated by the Nivotester FTL 325 N.

The following Endress+Hauser level limit switches are specified to EN 50227 (DIN 19234; NAMUR) or IEC 60947-5-6 and can be connected:

- LIQUIPHANT M with FEL 56
- LIQUIPHANT M with FEL 58
- LIQUIPHANT S (high-temperature) with FEL 56
- LIQUIPHANT S (high-temperature) with FEL 58

Also, all sensors specified to EN 50227 (DIN 19234; NAMUR) or IEC 60947-5-6 and contact switches with the appropriate resistance circuit can be connected. When contact switches are used without resistance circuit, alarm detection for short-circuit and signalling line interruption can be switched off for the appropriate channel.

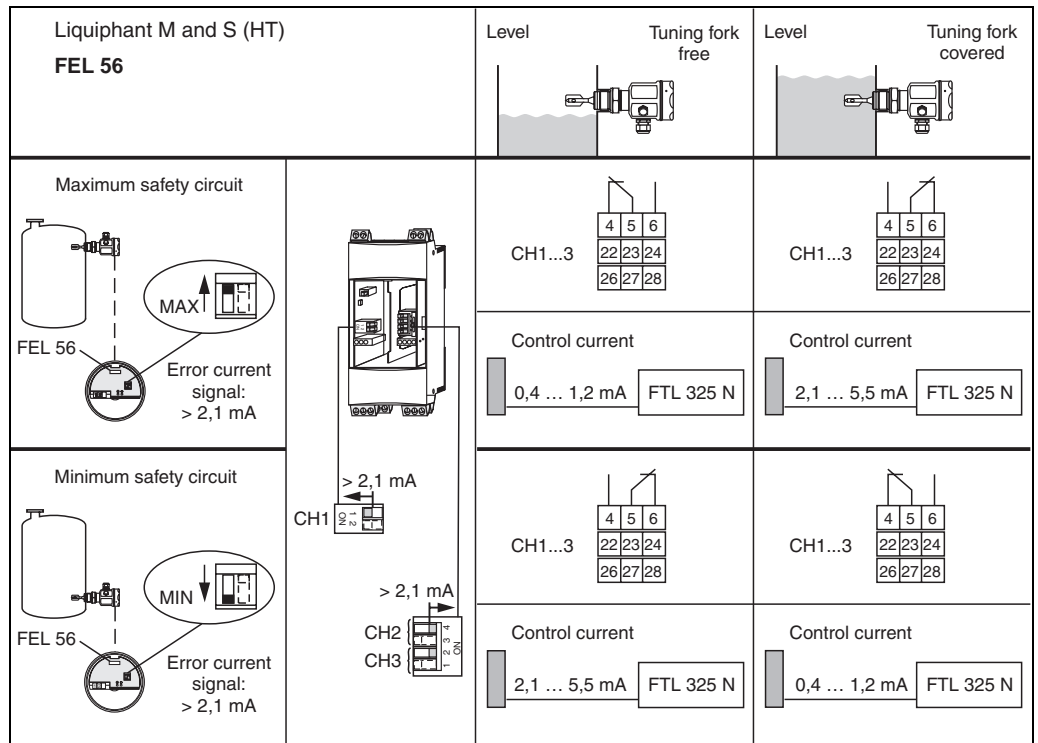

L00-FTL325Nx-15-06-xx-en-001

Function of the level limit signal and the current pulse dependent on level and fail-safe circuit.

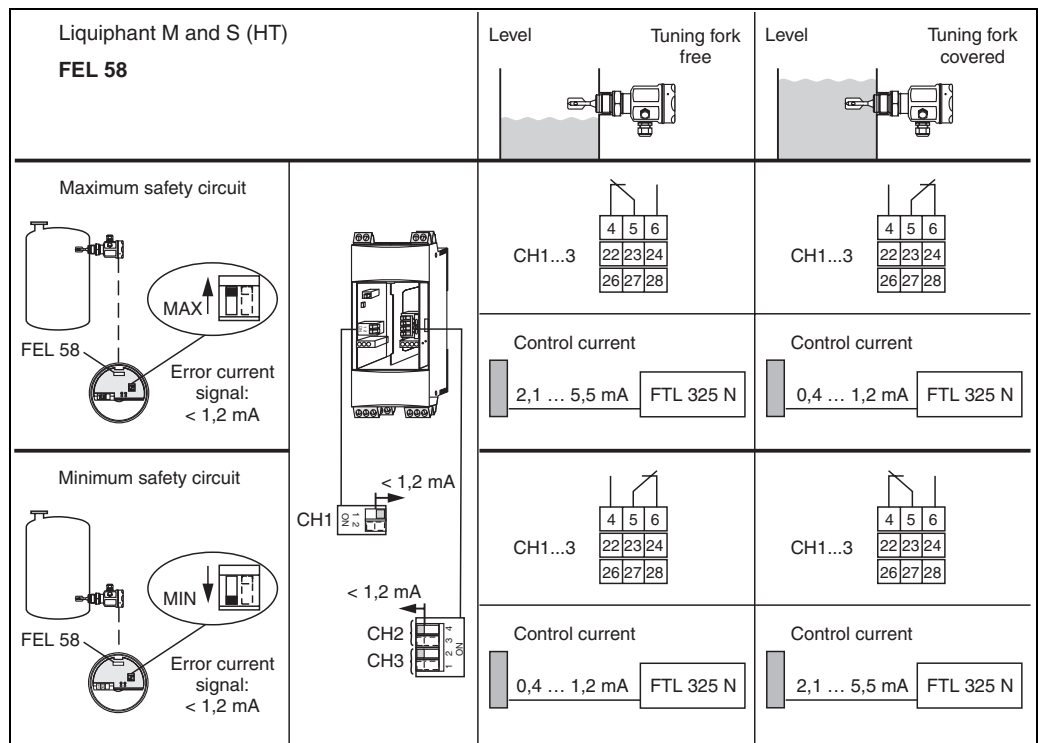

L00-FTL325Nx-15-06-xx-en-002

Function of the level limit signal and the current pulse dependent on level and fail-safe circuit.

Measuring system

A measuring device consists of one to three measuring sensors, a 1- or 3-channel Nivotester and control or signal devices. A Liquiphant M or S (high temperature) with FEL 56 and FEL 58 electronic inserts can be used as a measuring sensor. Alternatively, any number of sensors specified to DIN 50227 (NAMUR) or contact switches with appropriate resistance circuit can be used (see also NAMUR Module, page 2).

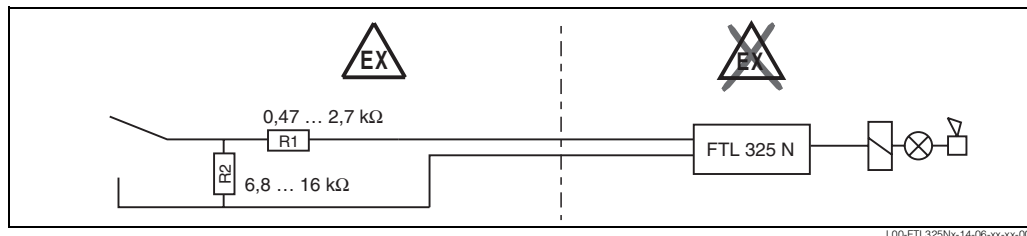

Contact switch with appropriate resistance circuit.

1-channel Nivotester FTL 325 N-#1#1

The measuring device of the one-channel instrument consists of:

- 1 measuring sensor
- 1-channel Nivotester
- control or signal devices

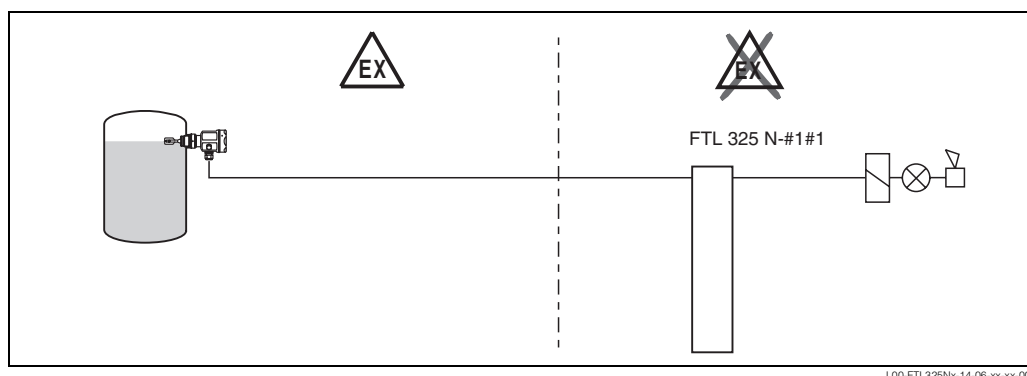

3-channel Nivotester FTL 325 N-#3#3

There are five possible variants of the measuring devices of the three-channel instrument.

1. When all three single channels are used for measuring the level limit, the measuring device consists of:
 - 3 measuring sensors
 - 3-channel Nivotester
 - control or signal devices

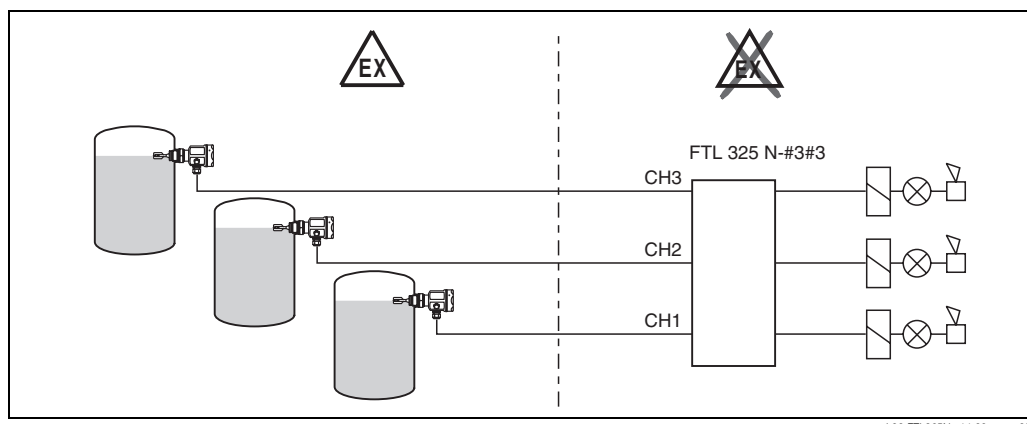

2. When channels CH2 and CH3 are used for two-point control Δs the measuring device consists of:
 - 2 measuring sensors
 - 3-channel Nivotester
 - control or signal devices

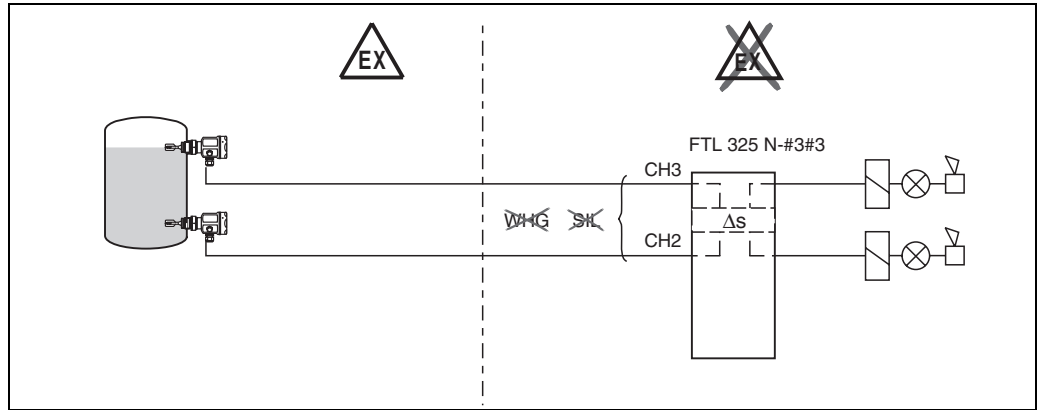

3. When channels CH2 and CH3 are used for two-point control Δs and channel CH1 for overspill protection, the measuring device consists of:
 - 3 measuring sensors
 - 3-channel Nivotester
 - control or signal devices

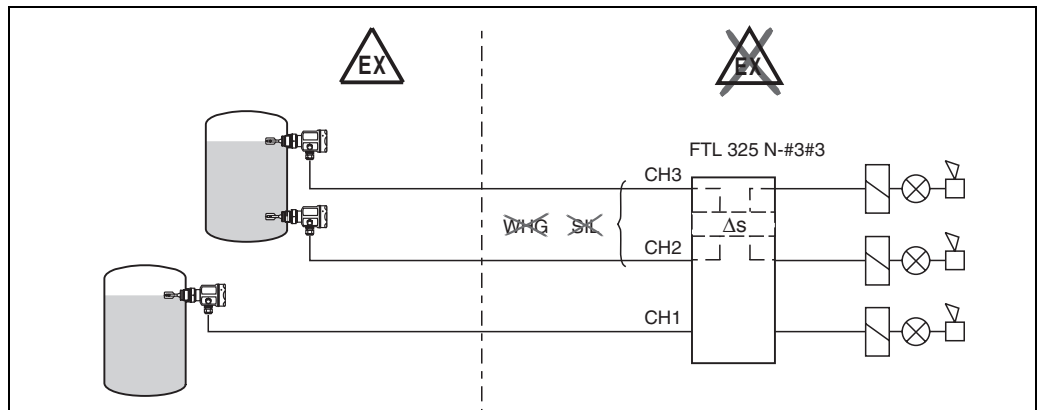

4. When channel CH2 is used for measuring the level limit with two level limit relays and channel CH1 is used for measuring other level limits, the measuring device consists of:
 - 2 measuring sensors
 - 3-channel Nivotester
 - control or signal devices

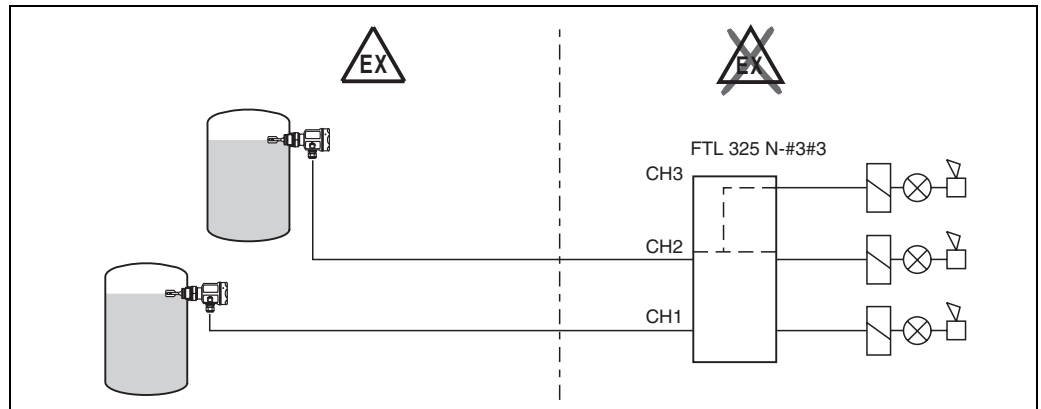

L00-FTL325Nx-14-06-xx-xx-006

5. When channel CH2 is used for measuring the level limit with two level limit relays, the measuring device consists of:
 - 1 measuring sensor
 - 3-channel Nivotester
 - control or signal devices

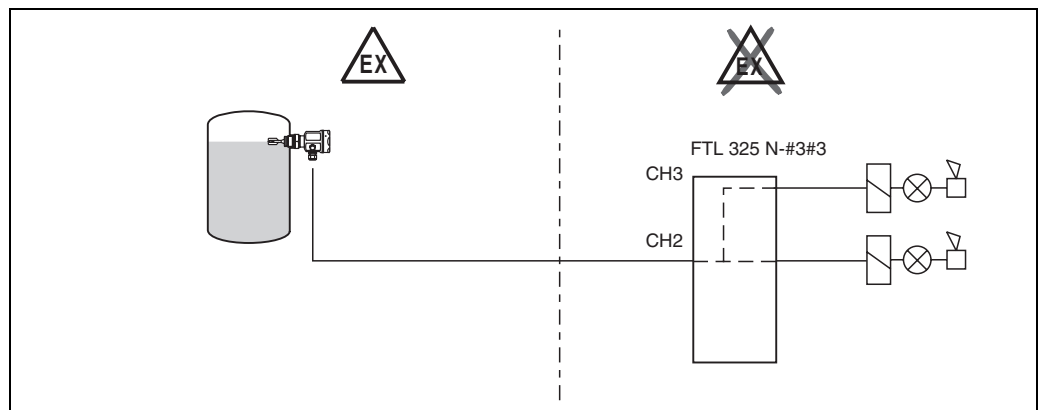

L00-FTL325Nx-14-06-xx-xx-007



Note!
As CH1 is not used, the alarm must be switched to "off".

Input parameters

Measured variable	The limit signal can be triggered at minimum or maximum height as required
Measuring range	The measuring range is dependent on the installation location of the sensors
Input signal	<ul style="list-style-type: none"> • Input FTL 325 N: galvanically isolated from power supply and output • Protection type: intrinsically safe [EEx ia] IIC • Connectable measuring sensors: <ul style="list-style-type: none"> – Liquiphant M FTL 50/51, FTL 50 H/51 H, FTL 51 C with electronic insert FEL 56 or FEL 58 – Liquiphant S (HT) FTL 70/71 with electronic insert FEL 58 or FEL 56 – Any number of sensors specified to EN 50227 (DIN 19234; NAMUR) or IEC 60947-5-6 – Contact switches with appropriate resistance circuit • Measuring sensor power supply: from the Nivotester FTL 325 N • Connecting line: two-wire, screening unnecessary • Line resistance: max. 25 Ω per wire • Signal transmission: current signal on supply line • Control current range: < 1.2 mA / > 2.1 mA • Line interruption monitoring < 200 μA and short-circuit > 6.1 mA (can be switched off) <p>Further details for installing measuring sensors outside explosion hazardous zones can be found in the appropriate certificates.</p>

Output parameters

Output signal	<ul style="list-style-type: none"> • Relay output per channel: one potential-free switch contact for the level alarm • Quiescent current safety circuit: The function of the quiescent current safety circuit is dependent on the setting made on the FEL 56 and FEL 58 sensors and on selection of the error current signal on the Nivotester. • Switch delay: approx. 0.5 s • Switching power of the relay contacts: <p style="margin-left: 20px;">U ~ max. 253 V I ~ max. 2 A P ~ max. 500 VA at $\cos \varphi \geq 0.7$</p> <p style="margin-left: 20px;">DC version: U = max. 40 V I = max. 2 A P = max. 80 W</p> • Life: at least 10^5 switching operations at maximum contact load • Function displays: LEDs for operation, level alarm and fault
Overvoltage category acc. to EN 61010	II
Protection class	II (double or increased insulation)
Fault signal	Relay dropped out; fault signal by red LEDs
Galvanic isolation	All input and output channels and relay contacts are galvanically isolated from each other

Power supply

Electrical connection

Terminal blocks

The removable terminal blocks are separated into intrinsically safe connections (at top of the instrument) and non-intrinsically safe connections (at bottom of the instrument). Also, the terminal blocks have different colours to make them more easily recognisable. Blue for the intrinsically safe section and grey for the non-intrinsically safe section. This difference helps to ensure safe wiring.

Connecting the measuring sensor

(at upper, blue terminal blocks)

The two-wire connecting line between the Nivotester FTL 325 N and the Liquiphant, Nivopuls or Soliphant measuring sensor can be either a commercially available installation cable or wires in a multi-wire cable for measuring purposes. Line resistance may be a maximum of 25 Ω per wire. If strong electromagnetic interference is expected, e.g. from machines or radio devices, a screened cable must be used. Only connect the screen to the ground connection, and not to the Nivotester.

Using the measuring sensor in explosion hazardous areas

Please observe all local regulations on explosion protection concerning the type and installation of intrinsically safe signal cabling.

Please refer to the Safety Instructions XA 134F for maximum permissible values of capacitance and inductance.

Connecting signal and control devices

(at lower, grey terminal blocks)

The relay function is dependent on the level and fail-safe circuit.

If an instrument is connected at high inductance (e.g. contactor, solenoid valve etc.), a spark suppressor must be installed to protect the relay contact.

Connecting the supply voltage

(at lower, grey terminal blocks)

For voltage variants, see the Ordering Information on page 14.

A fuse is built into the supply current circuit. This obviates the need to connect a fine-wire fuse in series. The Nivotester is equipped with reverse polarity protection.

Supply voltage

AC version:

- Voltage ranges: 85...253 V AC, 50/60 Hz

DC version:

- Voltage ranges: 20...30 V AC / 20...60 V DC
- DC supply: max. 60 mA (1-channel)
- DC supply: max. 115 mA (3-channel)
- Permissible residual ripple within tolerance: $U_{ss} = \text{max. } 2 \text{ V}$

The Nivotester is equipped with reverse polarity protection.

Power consumption

AC

1-channel: max. 1.75 W

3-channel: max. 2.75 W

DC

1-channel: max. 1.2 W (bei U_{\min} 20 V)

3-channel: max. 2.25 W (bei U_{\min} 20 V)

Accuracy

Settling time/length

Final switching status after switching on the power supply: approx. 10...20 s, depending on the connected measuring sensor

Operating conditions (Installation conditions)

Installation instructions

Operating location

The Nivotester must be housed in a switch cabinet outside the explosion hazardous area. A protective housing (IP65) for up to four 1-channel or two 3-channel Nivotesters is available for outdoor installation.

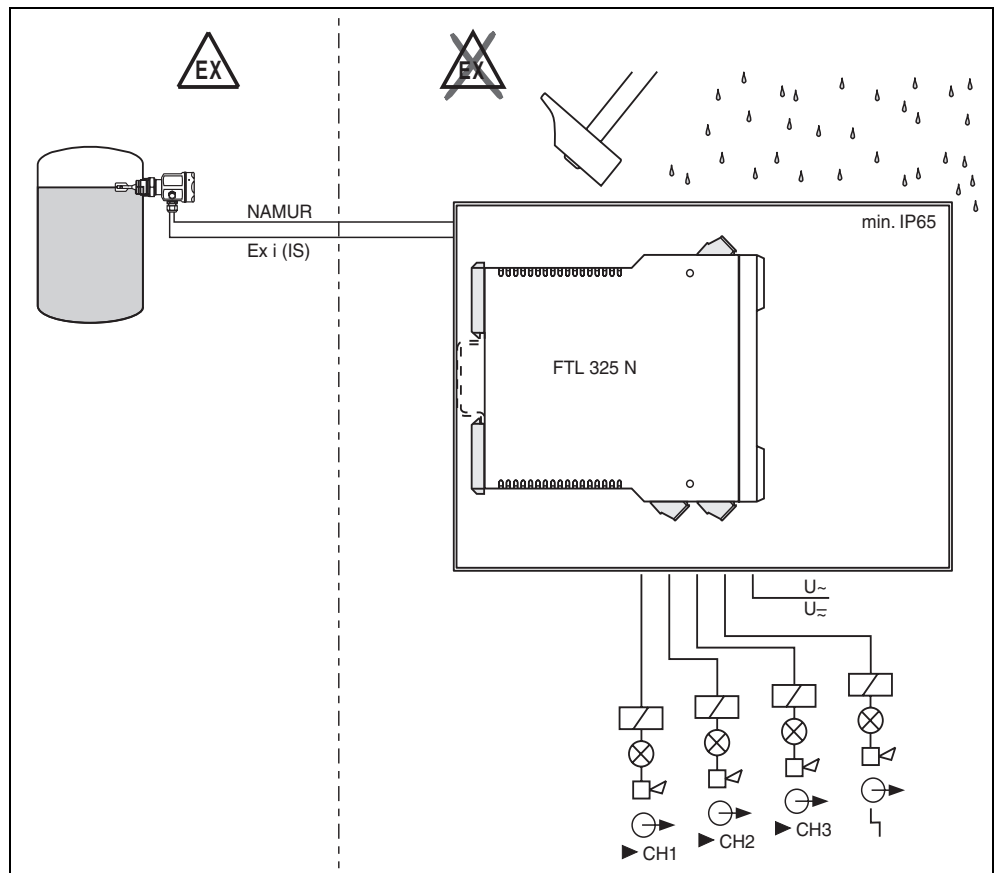

L00-FTL325Nx-11-06-xx-xx-001

Installation position

Vertical on DIN top-hat rail (to EN 60715).

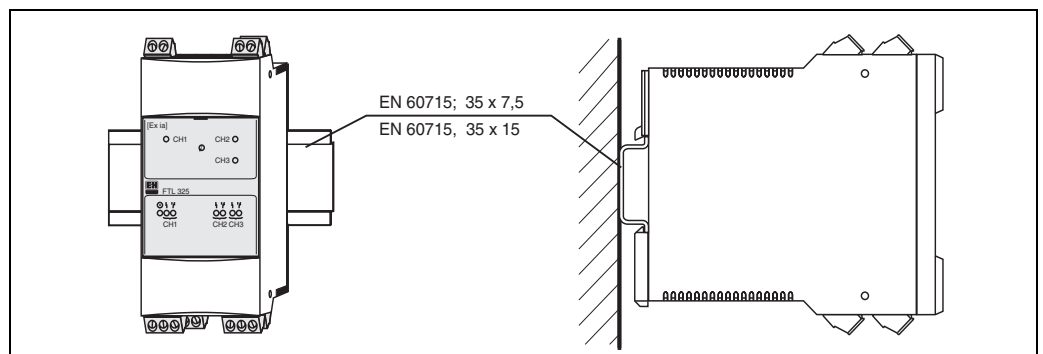

L00-FTL325xx-11-06-xx-xx-001

Operating conditions (Ambient conditions)

Operating location	Switch cabinet or protective housing
Permissible ambient temperatures	<p>For single installation</p> <ul style="list-style-type: none"> • $-20\text{ °C} \dots +60\text{ °C}$ ($-4\text{ °F} \dots +140\text{ °F}$) <p>For rail mounting without gaps</p> <ul style="list-style-type: none"> • $-20\text{ °C} \dots +50\text{ °C}$ ($-4\text{ °F} \dots +122\text{ °F}$) <p>Storage temperature</p> <ul style="list-style-type: none"> • $-20\text{ °C} \dots +85\text{ °C}$ (preferably at $+20\text{ °C}$) <p>Installation in protective housing</p> <ul style="list-style-type: none"> • $-20\text{ °C} \dots +40\text{ °C}$ ($-4\text{ °F} \dots +104\text{ °F}$) • Up to four 1-channel or two 3-channel Nivotesters fit in one protective housing. By combining these types of instrument, please note that only two 1-channel and one 3-channel are applicable. <p> Caution! Select a mounting location which protects the instruments from weather and impacts. Do not install them in direct sunlight. This is particularly important in regions with a warm climate.</p>
Climatic application class	<p>3K3 According to EN 60721-3-3</p> <p>3M2 According to EN 60721-3-3</p>
Ingress protection	IP20
Electromagnetic compatibility (EMC)	<p>Interference emission to EN 61326; Electrical Equipment Class B</p> <p>Interference immunity to EN 61326; Annex A (Industrial) and NAMUR Recommendation NE 21 (EMC)</p>

Mechanical construction

Construction, dimensions

- Housing: plastic rail-mounting housing (Minipac construction)
- Installation: on top-hat rail to EN 60715 - 35 x 7.5 or EN 60715 - 35 x 15
- Ingress protection to EN 60529; IP20



Note!
100 mm = 3.94 in

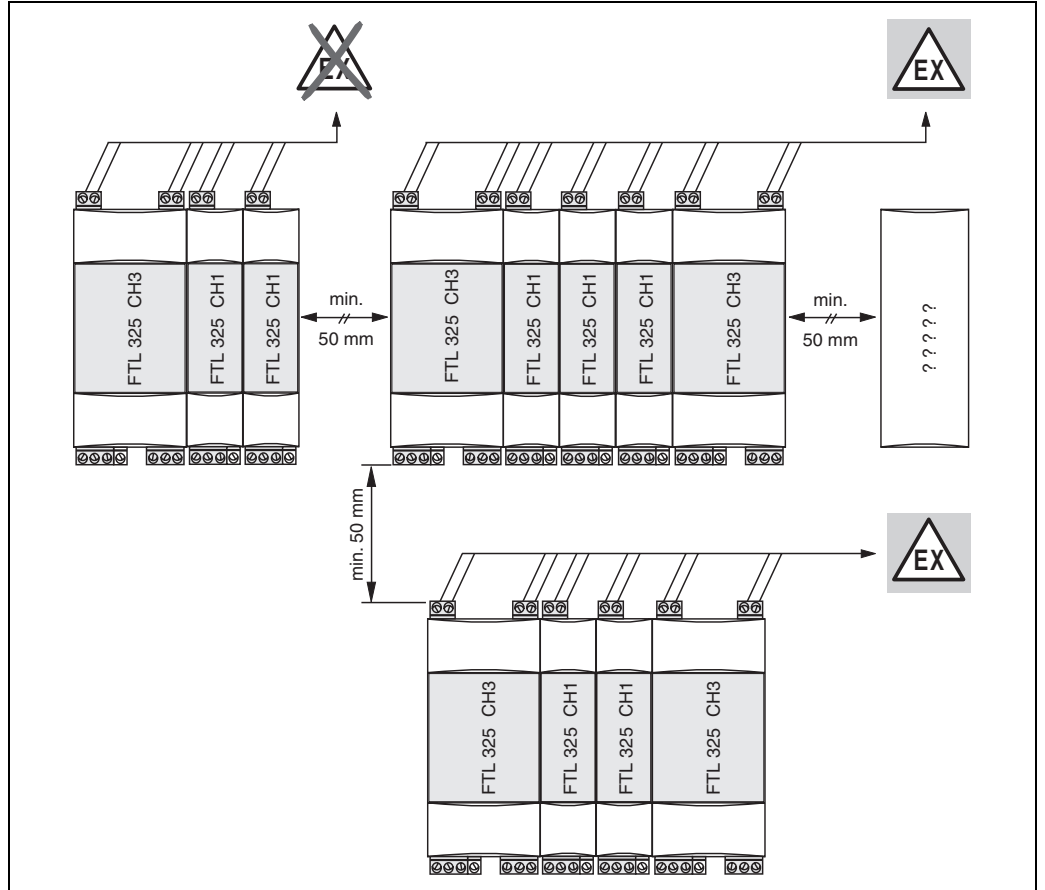

L00-FTL325xx-06-06-xx-xx-001

Dimensions

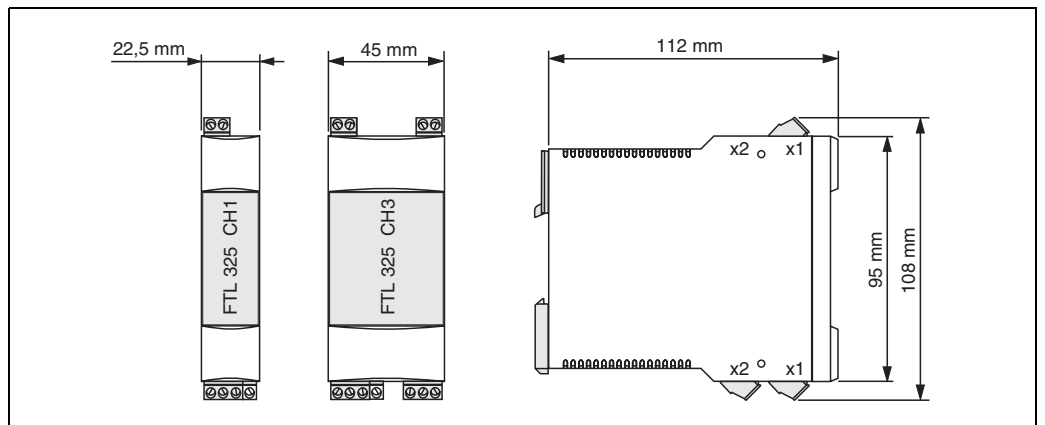

L00-FTL325xx-06-06-xx-xx-002

Weight

- 1-channel: approx. 148 g
- 3-channel: approx. 250 g

Materials

Housing

- Polycarbonat
- Colour: light grey, RAL 7035

Front cover

- Polyamid PA6
- Colour: blue

Fixing slide (for fixing to top-hat rail)

- Polyamid PA6
- Colour: black, RAL 9005

Connection terminals

1-channel

- 2 screw terminals: sensor power supply
- 3 screw terminals: limit value relay
- 2 screw terminals: fault signal relay
- 2 screw terminals: power supply

3-channel

- 3x2 screw terminals: channel 1 to 3 sensor power supply
- 3x3 screw terminals: limit value relay LV-Rel 1 to 3
- 2 screw terminals: fault signal relay
- 2 screw terminals: power supply

Connection cross section

max. 1 x 2.5 mm² or 2 x 1.5 mm²

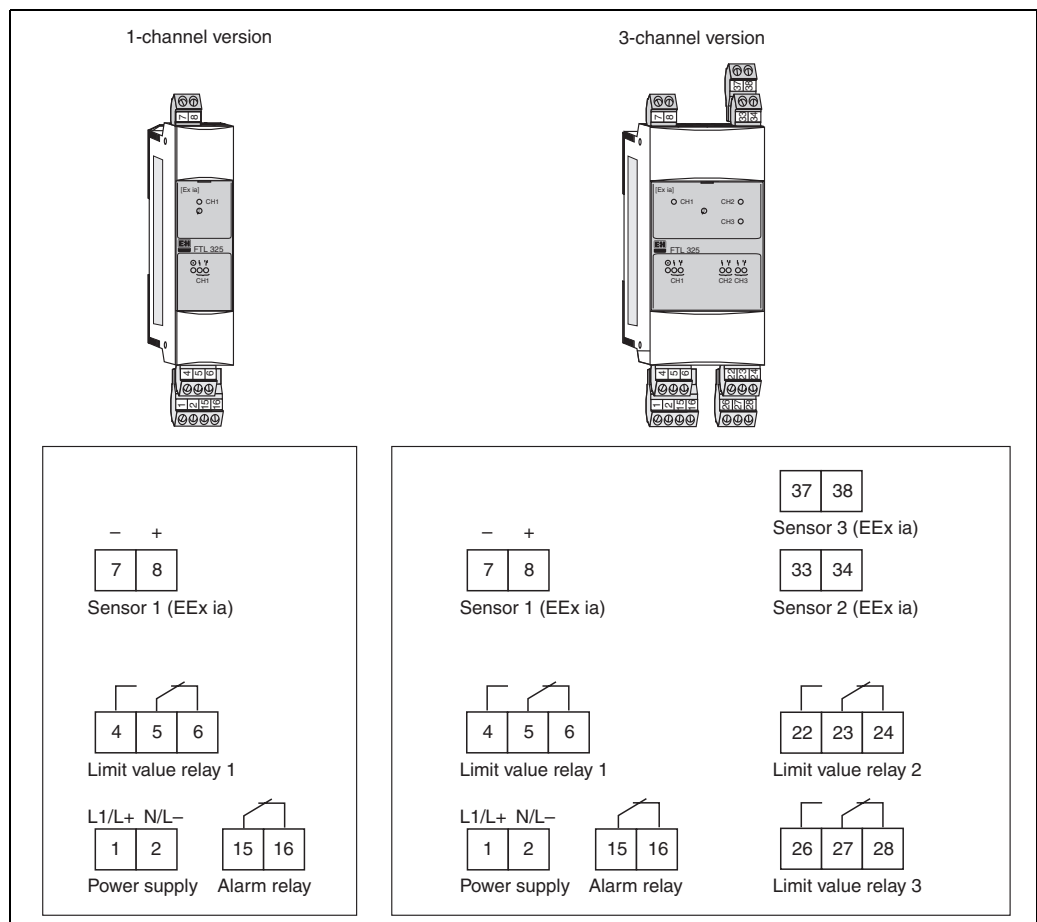

L00-FTL325xx-04-06-xx-en-001

Display and user interface

Operating concept

On-site setting with switches behind the hinged front panel

Display elements

- Green LED: standby
- One red LED per channel: fault signalling
- One yellow LED per channel: relay picked-up

Operating elements

1-channel instrument

- Switch for fault current signal 2.1 mA / 1.2 mA
- Switch for fault on/off setting

3-channel instrument

- Switch for fault current signal 2.1 mA / 1.2 mA
- Switch for fault on/off setting
- Switch for "Single channel" function (up to three channels)
- Switch for function "Δs"
- Switch for one channel with "two parallel switched limit value relays"

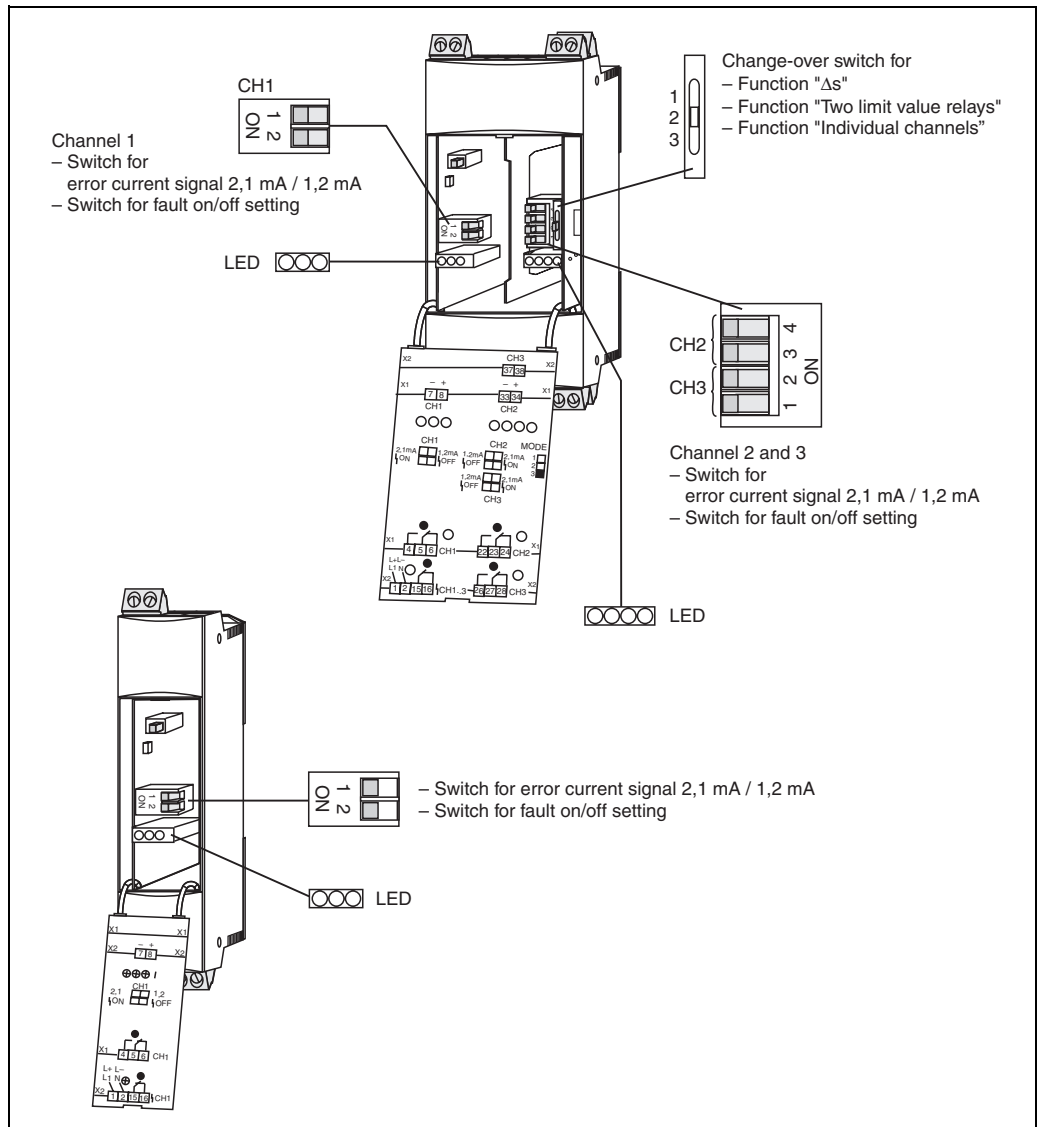

L00-FTL325Nx-19-06-xx-en-001

Certificates and approvals

CE mark	The device meets the statutory requirements of EC directives. Endress+Hauser confirms the successful testing of the device by affixing the CE mark.
Ex approval	The Endress+Hauser sales office provides information on the currently suppliable Ex versions (ATEX EEx ia; FM IS; CSA IS). All data relevant for explosion protection can be found in separate Ex documentation (see: Supplementary Documentation). This can be viewed as necessary.
Protection type	[EEx ia] IIC
Overspill protection	WHG
External standards and guidelines	External standards and guidelines which were met during the design and development of the Nivotester FTL 325 N. <ul style="list-style-type: none"> • EN 50227 (DIN 19234; NAMUR) or IEC 60947-5-6 Interface (level limit) to NAMUR Recommendations • EN 60529 Type of ingress protection for housing (IP Code) • EN 61010 Safety specifications for electrical measurement, control and laboratory instruments • EN 61326 Interference emission (Class B apparatus), interference immunity (Appendix A - Industry) • IEC 61508 / IEC 61511 Functional safety of safety-relevant electrical/electronic/programmable electronic systems (E/E/PES)
Functional safety	SIL1 / SIL2 connected with FEL 58 for protection functions as overspill protection. Please note Safety Manual SD 161F!

Ordering information

Nivotester FTL 325 N

10		Certificates	
F		ATEX II (1) GD [EEx ia] IIC	
H		ATEX II (1) GD [EEx ia] IIC, WHG, SIL2 (IEC 61508 / IEC 61511)	
O		FM IS	Cl. I, II, III Div.1 Group A-G
P		FM IS	Cl. I, II, III Div.1 Group A-G, SIL2 (IEC 61508 / IEC 61511)
S		CSA IS	Cl. I, II, III Div.1 Group A-G
T		CSA IS	Cl. I, II, III Div.1 Group A-G, SIL2 (IEC 61508 / IEC 61511)
V		* TIIS, Ex ia IIC	
W		* TIIS, Ex ia IIC, SIL2 (IEC 61508 / IEC 61511)	
		* in preparation	
20		Version	
		1	Top-hat rail installation 1-channel 22.5 mm
		3	Top-hat rail installation 3-channel 45 mm
		9	Special design
30		Voltage supply	
		A	Power supply 85... 253 V AC, 50/60 Hz
		E	Power supply 20... 30 V AC / 20... 60 V DC
		Y	Special design
40		Ausgang	
		1	1x level SPDT + 1x alarm SPST
		3	3x level SPDT + 1x alarm SPST
		9	Special design
FTL 325 N		Complete product designation	

Accessories

Protective housing

The protective housing of ingress protection class IP66 is equipped with an integrated top-hat rail and is closed by a transparent cover which can also be lead-sealed.

Dimensions:

W 180 / H 182 / D 165

Colour:

Light grey RAL 7035

Parts number (PN) 52010132

Supplementary documentation

System Information (SI)

- Liquiphant M
SI 040F/00/en

Technical Information (TI)

- Liquiphant M
FTL 50/51, FTL 50 H/51 H
Measuring sensor for level limit detection in liquids
TI 328F/00/en
- Liquiphant M
FTL 51 C
Measuring sensor for level limit detection in liquids
with highly corrosion-resistant coating
TI 347F/00/en

- Liquiphant S (high temperature)
FTL 70/71
Measuring sensor for level limit detection in liquids
for measuring medium temperatures of up to 280 °C
TI 354F/00/en
- Protective housing
TI 367F/00/en

**Operating Instructions
(KA)****1-channel:**

- Nivotester
FTL 325 N-#1#1
1-channel isolating amplifier
KA 170F/00/a6

3-channel:

- Nivotester
FTL 325 N-#3#3
3-channel isolating amplifier
KA 171F/00/a6

Certificates**ATEX:**

- Nivotester
FTL 325 N
XA 134F/00/a3

DIBt:

- Liquiphant M, Liquiphant S
FTL 50/51, FTL 50 H/51 H, FTL 51 C, FTL 70/71
ZE 233F/00/de

SIL:

- Liquiphant M/S + Nivotester FTL 325 N
SD 161F/00/en

Endress+Hauser GmbH+Co.

Instruments International
P.O. Box 2222
D-79574 Weil am Rhein
Germany

Tel. (07621) 975-02
Tx 773926
Fax (07621) 975 345
e-mail: info@ii.endress.com

Internet:

<http://www.endress.com>

Endress + Hauser
The Power of Know How

